

Expander / gate circuit description

An expander is essentially the opposite of a compressor, since it seeks to increase (expand) the dynamic range of the input signal, rather than reduce it. Normally it acts toward the lower end of the dynamic range of the signal, the chief purpose being to reduce unwanted noise and spurious when the desired audio signal is of a low level, or absent. If it acts in a linear manner, i.e. the attenuation is proportional in some manner to the input signal level, then the action is normally termed (downwards) *expansion*. If it switches sharply between an attenuating or non-attenuating state when the input signal crosses a set threshold level, it is usually termed *gating*. The circuit described below offers both modes of operation, with adjustable *Threshold* (the input level below which gain reduction occurs), *Depth* (maximum level) of attenuation, *Release* (rate of onset of attenuation) and *Attack* (rate of removal of attenuation).

Figure 1 shows the schematic, in which OP1 is the audio gain control element. A **NSL-32SR3S** is used here, because of its rapid response and high **OFF** resistance: the maximum attenuation of the circuit is directly dependent on this and the load resistance ($R3+R4$). OP1 is used in series with OP2 which should be from the same grading. Used this way, with the same current flowing through each coupler's LED, the attenuation of the circuits OP1/ $R3+R4$ and OP2/ $R35$ is identical. So as the side chain circuitry sets the attenuation of OP2/ $R35$, the audio will follow.

The input to the side chain is through VR1, which sets the Threshold over the range +10 dBu (clockwise) to -30 dBu. The signal from the wiper passes to IC2A, which is a high gain amplifier with clipping diodes DZ1 and DZ2 to limit the output signal swing to a linear range of +/-2.5 V. Low voltage zener diodes start to conduct a long way below their rated 20 mA clamping voltage. The output of IC2A is rectified by IC2B/IC3A and associated diodes, and held on capacitor C4, which is buffered by IC3B. From here the signal goes 2 ways: to IC4A for the expand function and to IC5A for the gate. IC4A subtracts the rectified signal from the 5 V reference voltage to give an output that varies from +5 V (signal way below threshold) -0.6 V (signal more than 3 dB above threshold) in a linear manner. IC5 compares the output of IC3B with a 0.95 V reference voltage. When the signal is below threshold and the gate is "closed" (maximum attenuation), the output of IC5A is low, and the bottom end of C11 is charged down to V_- by constant current source Q2. When the signal goes above the set threshold, the output of IC5A goes positive, turning on Q1, discharging C11. When the voltage on the bottom of C11 rises above 0 V, IC5B's output switches from high to low: R31 and DZ4 clips this voltage swing to give a control signal that swings from +5.1 V (gate shut) to -0.6 V (gate open). S2 selects which of the control signals is applied to the time constant and opto-servo circuitry.

The heart of the time constant circuitry is C13, which, in the attenuated or closed state, is charged up to a voltage between +3.3 V and +5 V that is set by the depth control VR5, through the Release control VR3. As soon as the input to IC4B through R28 falls below 5 V (input approaching or crossing the set Threshold), its output rises turning on Q3 rapidly reducing the voltage on C13 to match the input, at a rate set by the *Attack* control VR4. This shaped control voltage is fed to IC6B which forms a servo loop around the OP2/ $R35$ attenuator, which is buffered by IC6A to prevent loading effects. This control loop acts to keep the same voltage across OP2 as exists across C13. By regulating the LED current via Q4, R33 and C12 provide frequency compensation to keep stability. R37 adds a little bit of +ve offset to ensure that the couplers are not driven too hard on, and always turn off fully in spite of any opamp V_{os} variations. The output of IC6A can also be used to drive a meter to indicate the amount of gain reduction: as it mirrors the voltage on C13, the range is between 0 V (no attenuation) and +5.1 V (>60dB attenuation).

Figure 2 shows the response of the circuit in expand mode with minimum and maximum Thresholds, and **Figure 3**, the response with Threshold set to maximum, and the depth control set to ACW, mid and CW positions. **Figures 4** and **5** show the response for the same control positions with the function set to gate. Audio performance of the prototype was pretty good, THD being approx 0.0015% at 1KHz with +14 dBu input and no attenuation, and output noise with the input muted better than -105 dBu.

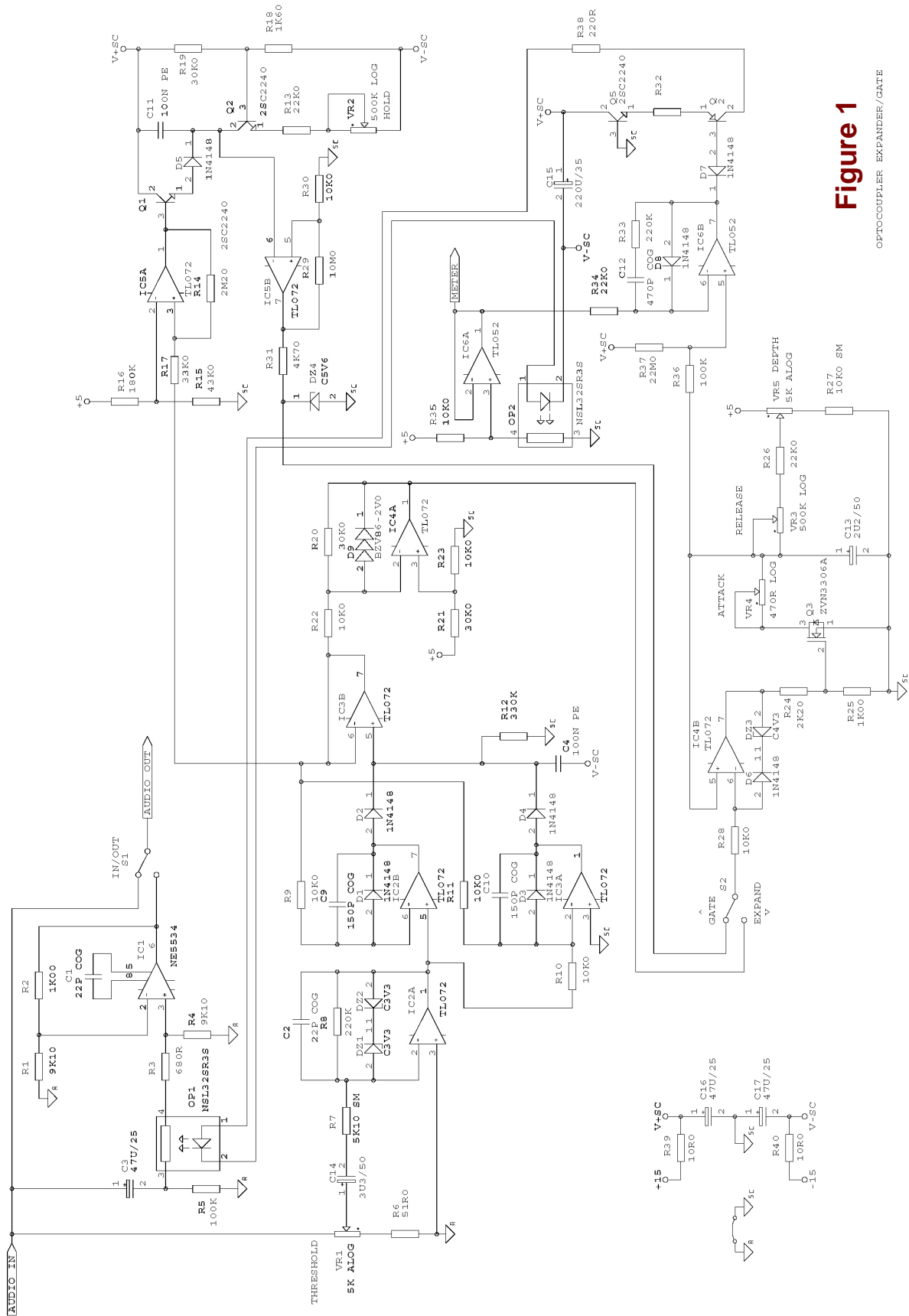

Figure 1

OPTOCOUPLER EXPANDER /GATE

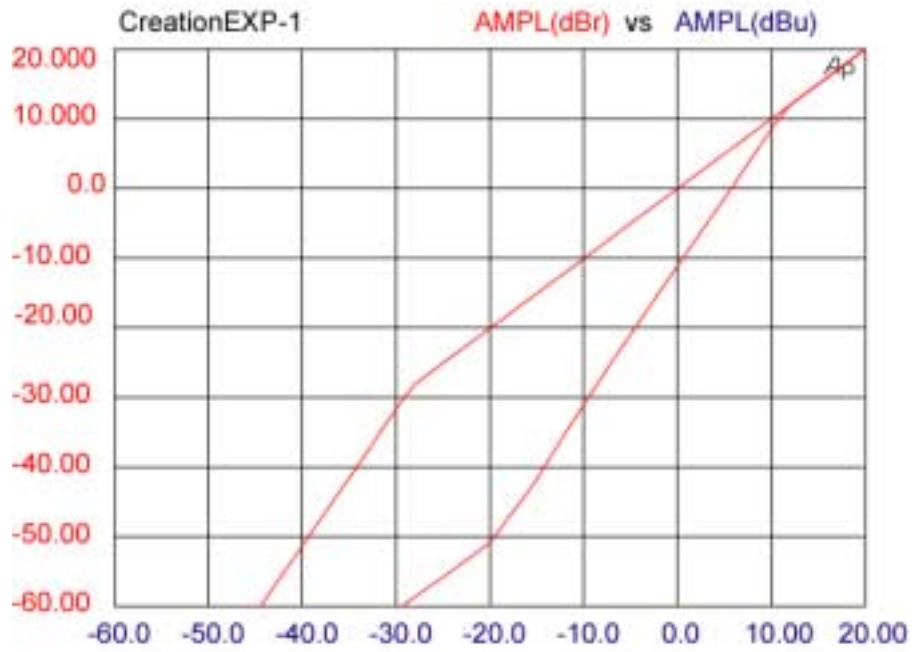

Figure 2

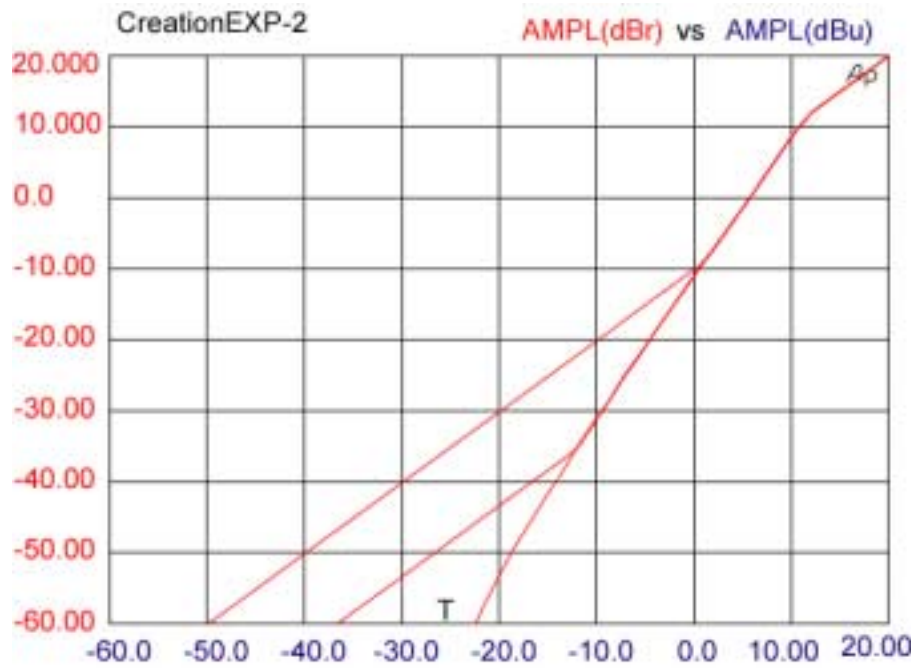

Figure 3

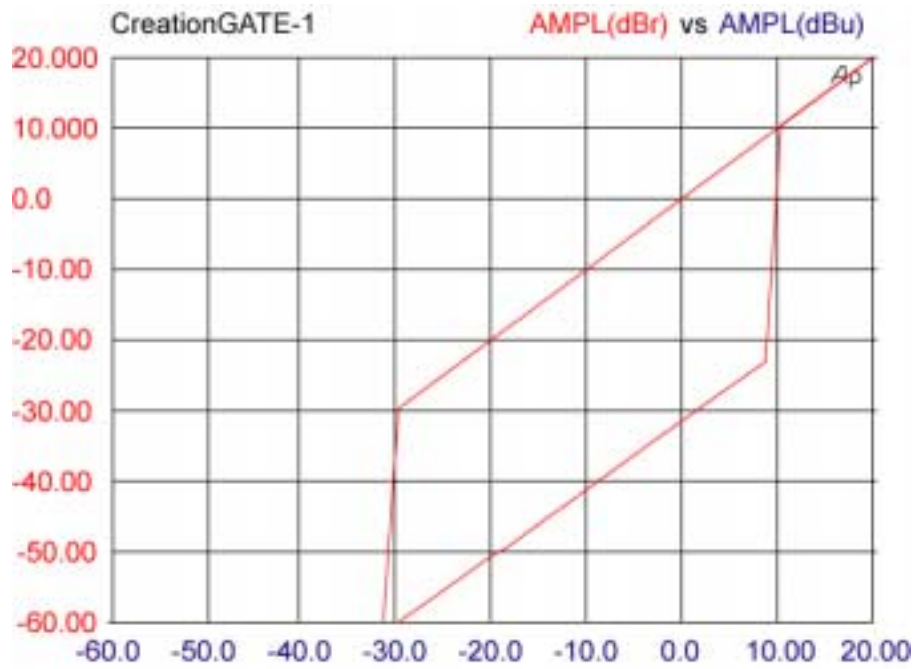

Figure 4

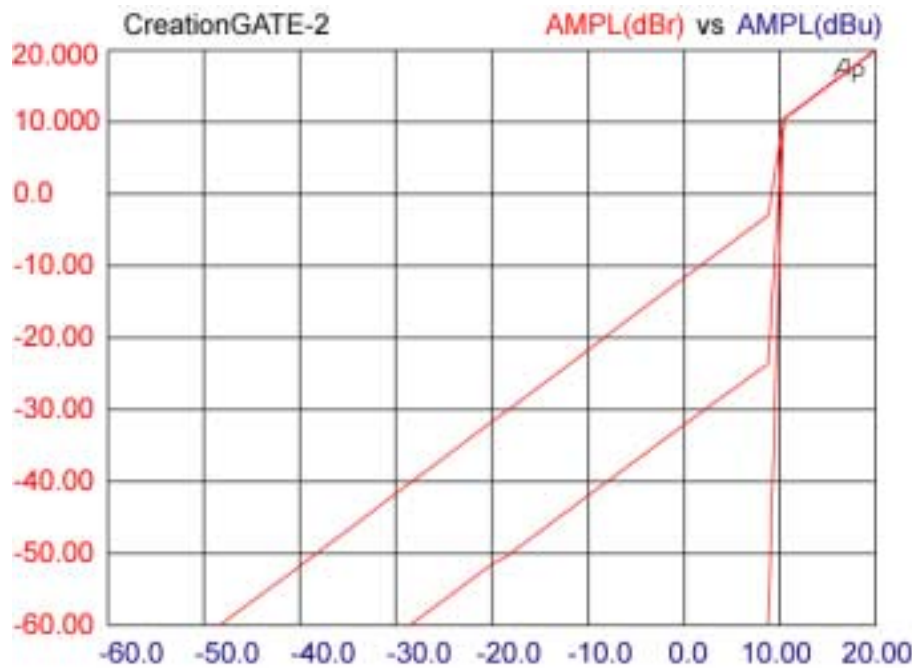

Figure 5