

Features

- Planar photodiode
- Low capacitance
- Fast switching time
- Low leakage current
- Linear response vs irradiance
- Multiple dark current ranges available

Description

The planar photodiode is designed to operate in either photoconductive or photovoltaic modes. High sensitivity and low dark current allow use in even low irradiance applications. The photodiode is supplied on a ceramic base with a clear epoxy dome package.

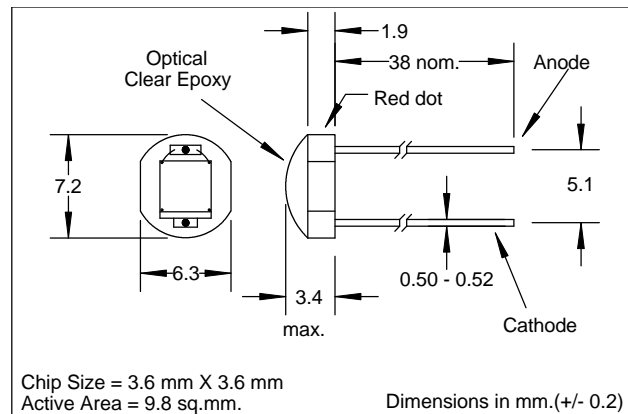

Absolute Maximum Ratings

Storage Temperature	-20°C to +75°C
Operating Temperature	-20°C to +75°C
Soldering Temperature (3)	260°C

- Notes: (1) Ee = source @ 2854°K.
(2) Ee = source @ $\lambda = 880 \text{ nm}$
(3) >2 mm from case for < 5 sec.

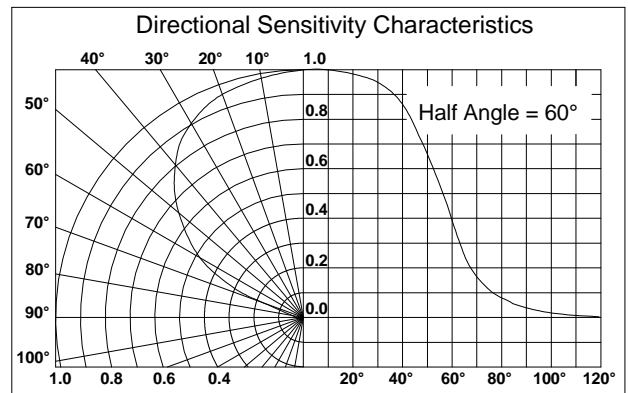

Electrical Characteristics (T_A=25°C unless otherwise noted)

Symbol	Parameter	MIN	TYP	MAX	UNITS	TEST CONDITIONS
I _{SC}	Short Circuit Current	450	700		μA	V _R =0V, Ee=25mW/cm ² (1)
V _{OC}	Open Circuit Voltage		0.40		V	Ee=25mw/cm ² (1)
I _D	Reverse Dark Current:					
	SLD-70C2A			100	nA	V _R =100mV, Ee=0
	SLD-70C2B			100	nA	V _R =5V, Ee=0
	SLD-70C2C			20	nA	V _R =5V, Ee=0
	SLD-70C2D			5	nA	V _R =5V, Ee=0
	SLD-70C2E			1	nA	V _R =5V, Ee=0
C _J	Junction Capacitance		180		pF	V _R =0, Ee=0, f=1MHz
t _R	Rise Time		4		μs	V _R =5V, R _L =1kΩ (2)
t _F	Fall Time		6		μs	V _R =5V, R _L =1kΩ (2)
TC _I	Temp. Coef., I _{SC}		+0.2		%/°C	(1)
V _{BR}	Reverse Breakdown Voltage	50			V	I _R =100μA
λ _P	Maximum Sensitivity Wavelength		930		nm	
λ _R	Sensitivity Spectral Range	400		1100	nm	
θ _{1/2}	Acceptance Half Angle		60		deg	(off center-line)

Specifications subject to change without notice.

101407 REV 4